

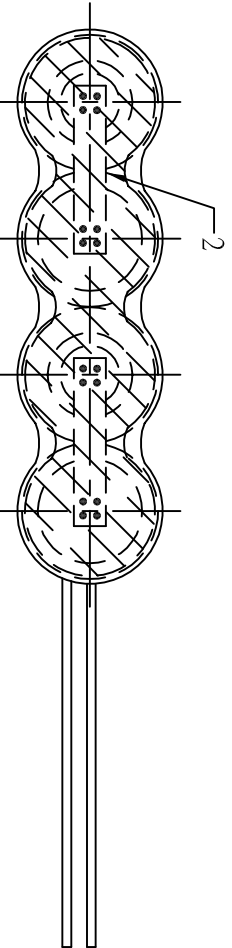

REVISIONS

| LTR | DESCRIPTION | SIGNATURE AND DATE | DWN | CHK | AUTH |
|-----|-------------|--------------------|-----|-----|------|
|     |             |                    |     |     |      |

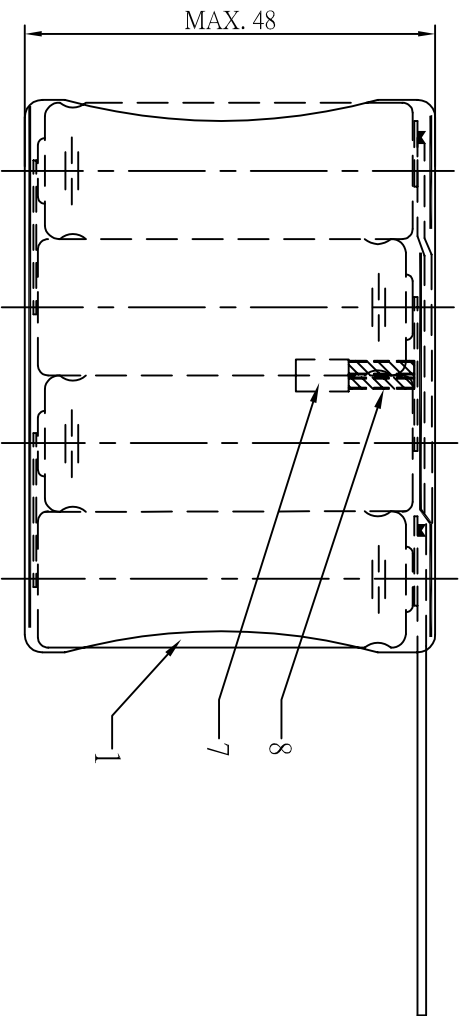
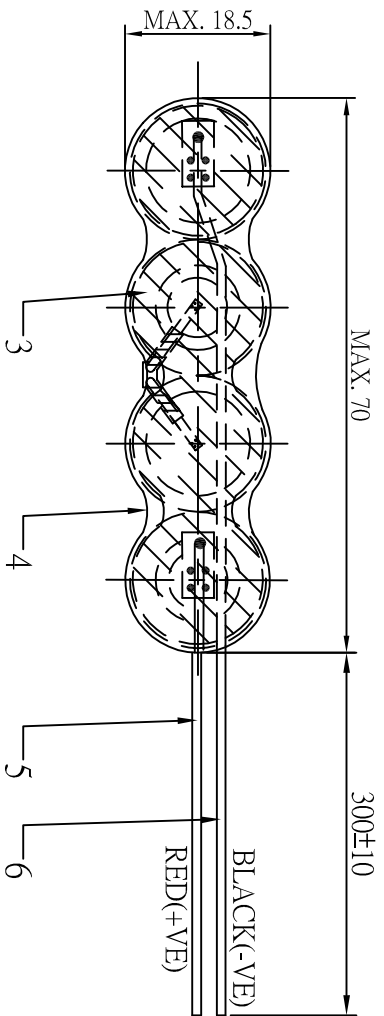

|     |               |                          |
|-----|---------------|--------------------------|
| 8   | SHRINK030     | HEAT SHRINKAGE SLEEVE    |
| 7   | T4MM75A       | THERMOSTAT               |
| 6   | WIRE20UL1015B | WIRE:AWG#20 UL1015,BLACK |
| 5   | WIRE20UL1015R | WIRE:AWG#20 UL1015,RED   |
| 4   | SHRINK18062W  | SHRINKAGE SLEEVE,WHITE   |
| 3   | AFKRED        | FIBRE PAPER,RED          |
| 2   | NS15050       | NICKEL STRIP             |
| 1   | NT160AHT      | UNIT CELL                |
| No. | PART NUMBER   | DESCRIPTION              |

**STUDIO DEL SOLE INC.**

TITLE: AF SIZE PACK CONFIGURATION (4B6Z)

DWG. NO.: ZED7439

REV. NO.: 0

SIGNATURE

DATE

Division: PCD

CELL TYPE: AF SIZE

DRAWN: WC LAN 22.JUL.04

CHKD: DANNY CHUNG 22.JUL.04

APPD: GILBERT SIN 22.JUL.04

Page 2 of 2

SCALE: Not in scale

NOTICE:  
1.DO NOT SCALE THIS DRAWING  
2.REMOVE ALL SHARP EDGE  
UNLESS OTHERWISE SPECIFIED

DIMENSIONS ARE IN mm AND  
INCLUDE PLATED FINISHES  
\* TOLERANCE REQUEST:  
NO DEC.PT. ±0.30  
1 DEC.PT. ±0.10  
2 DEC.PT. ±0.05