

MAX 86.5

300:10

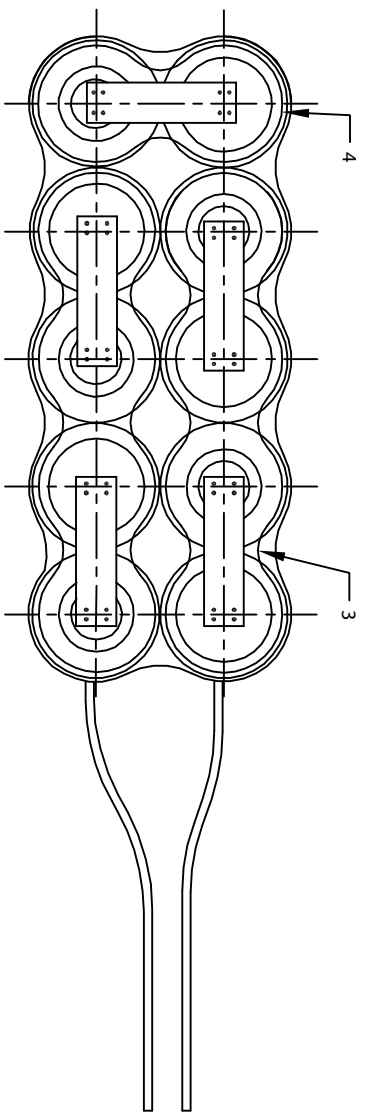
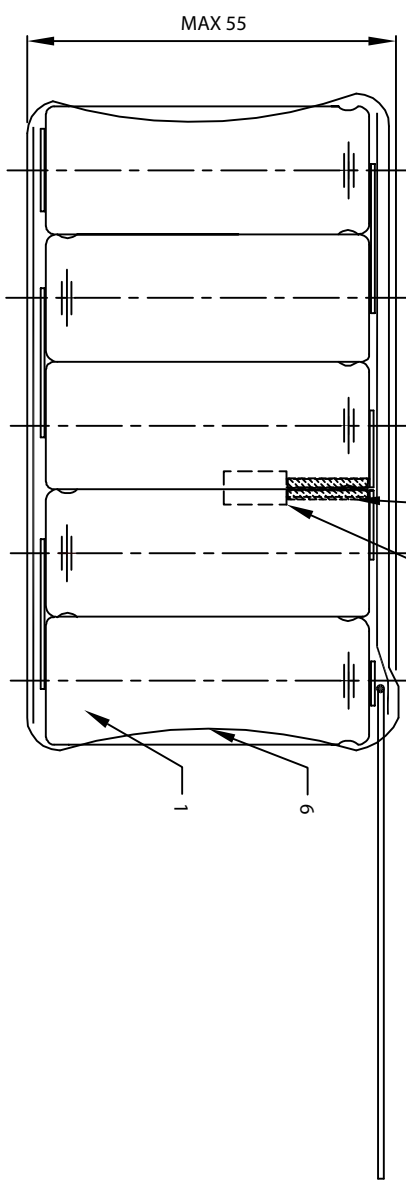
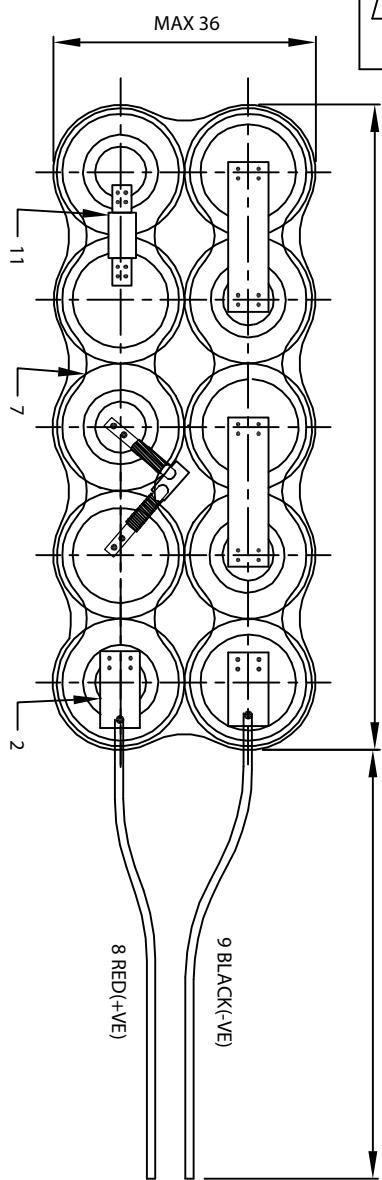

| REVISIONS |             |                    |      |
|-----------|-------------|--------------------|------|
| LTR       | DESCRIPTION | SIGNATURE AND DATE |      |
|           |             | DWN                | CHK  |
|           |             |                    | AUTH |

CIRCUIT DIAGRAM:

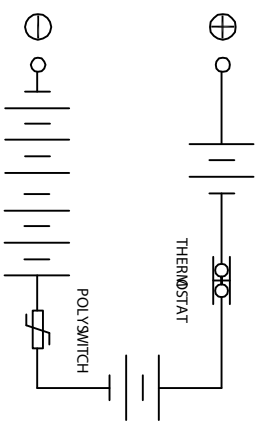

|     |              |                         |
|-----|--------------|-------------------------|
| 11  | PS-RS-P350F  | POLY SWITCH             |
| 10  | SHRINK020    | HEAT SHRINK TUBE BLACK  |
| 9   | WRE20UL1015B | WIRE AWG#20UL1015 BLACK |
| 8   | WRE20UL1015R | WIRE AWG#20UL1015 RED   |
| 7   | AFK5BRRED    | FBRE PAPER, RED         |
| 6   | SHRINK10088W | SHRINKAGE SLEEVE WHITE  |
| 5   | BW-DCP-75C   | THERMOSAT 75 C          |
| 4   | AFK2BRRED    | FBRE PAPER, RED         |
| 3   | AFK4BRRED    | FBRE PAPER, RED         |
| 2   | NS15050      | WELDING TAG             |
| 1   | NT2104HT     | UNIT CELL               |
| No. | PART NUMBER  | DESCRIPTION             |

# STUDIO DEL SOLE INC.

TITLE: AF SIZE PACK CONFIGURATION (10Y6Z)

DWG NO.: PRE0573 REV. NO.: 0

## SIGNATURE

DATE

Division: HZHMVB

SCALE: Not in scale

| DRAWN | XL ZHENG  | 20 May, 11 |
|-------|-----------|------------|
| CHKD  | KEITH SUN | 20 May, 11 |
| APPD  | KCLEUNG   | 20 May, 11 |

NOTICE:  
 1. DO NOT SCALE THIS DRAWING  
 2. REMOVE ALL SHARP EDGE  
 UNLESS OTHERWISE SPECIFIED

DIMENSIONS ARE IN mm AND  
 INCLUDE PLATED FINISHES  
 \* TOLERANCE REQUEST:  
 NO DEC.PT. 0.50  
 1 DEC.PT. 0.10  
 2 DEC.PT. 0.05

CELL TYPE: AF-SIZE  
 Page: 2 of 2